

CONTROL ROOM FLAT
14'-0" ABL

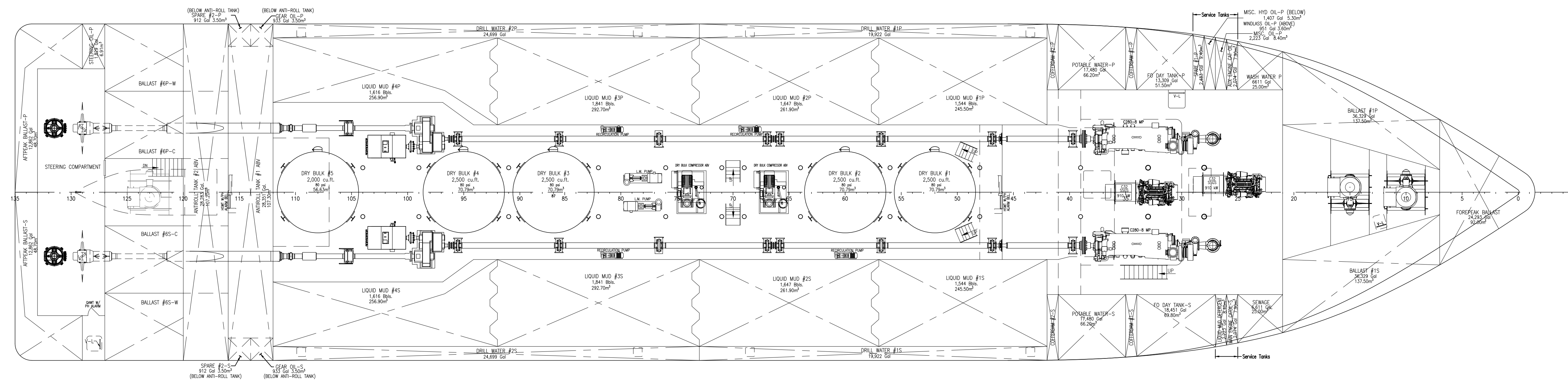

ABOVE TANK TOP PLAN

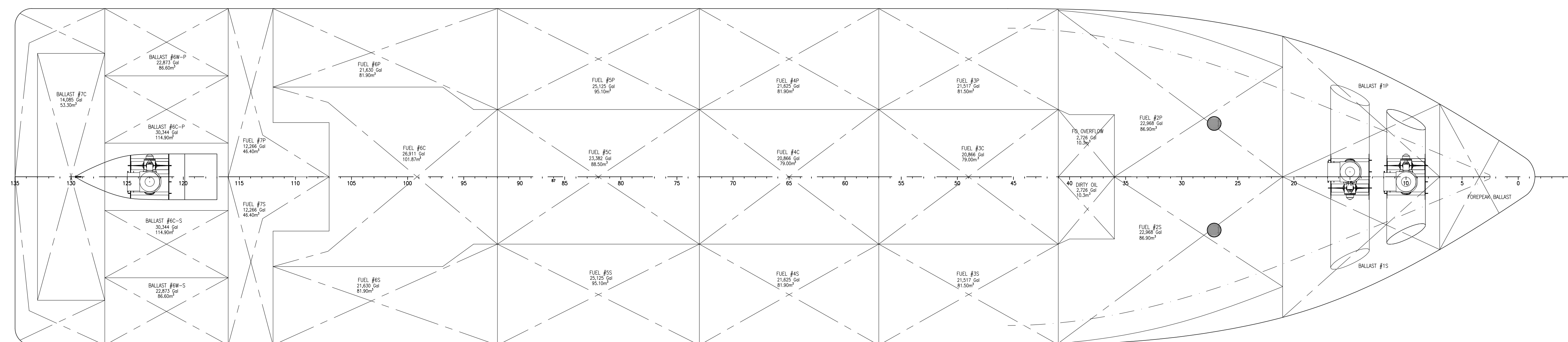

TANK TOP

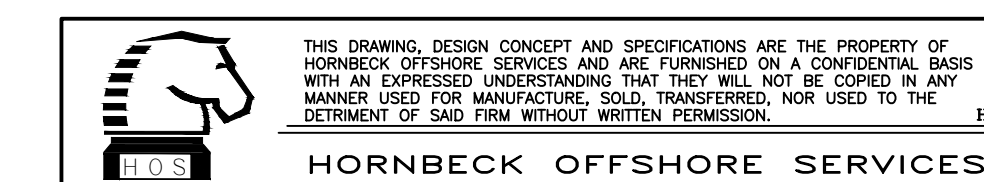

OUTBOARD PROFILE & GENERAL ARRANGEMENT		SIZE
TASK No. 7582	DRAWING No. 1.001	D
HULL No. 260	SY: NAS	2
SCALE: 3/32"=1'-0"		REV.
DATE: 03/03/22		
SHEET 2 OF 3		

24

23

22

21

20

19

18

17

D

D

C

C

B

B

A

A

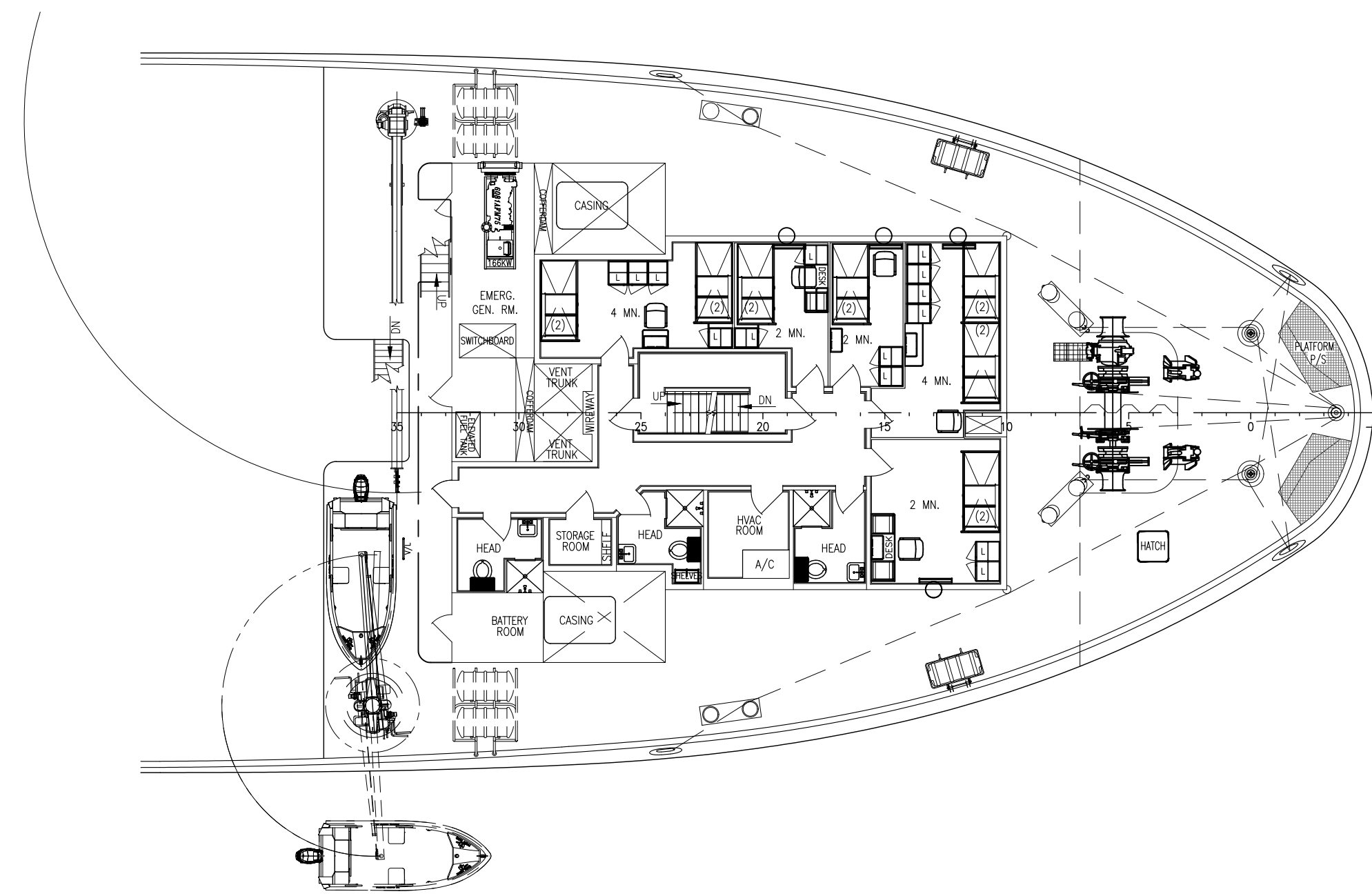

01 DECK PLAN
34'-2" ABL (@ FR5)

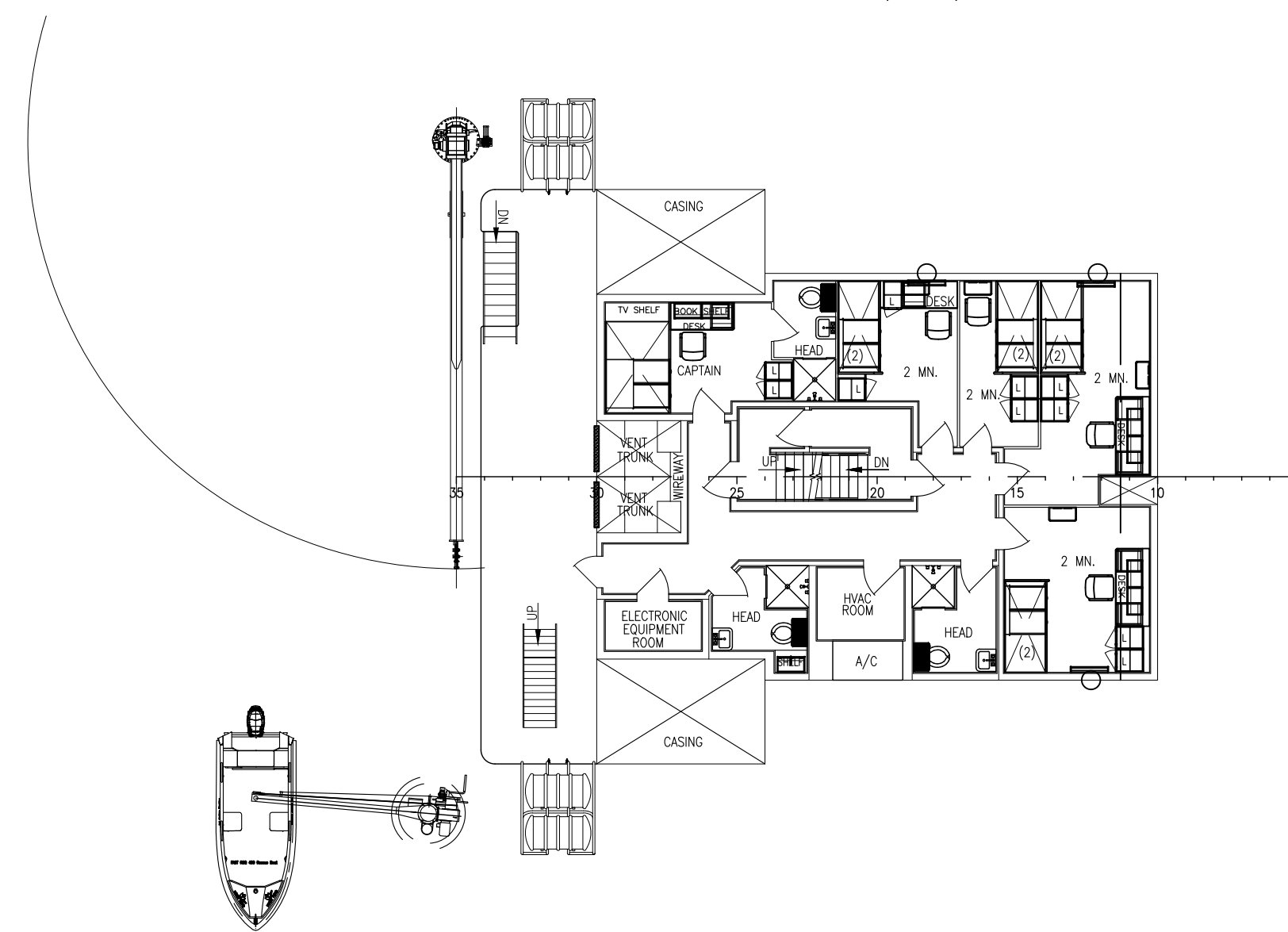

02 DECK PLAN
42'-5 5/8" ABL

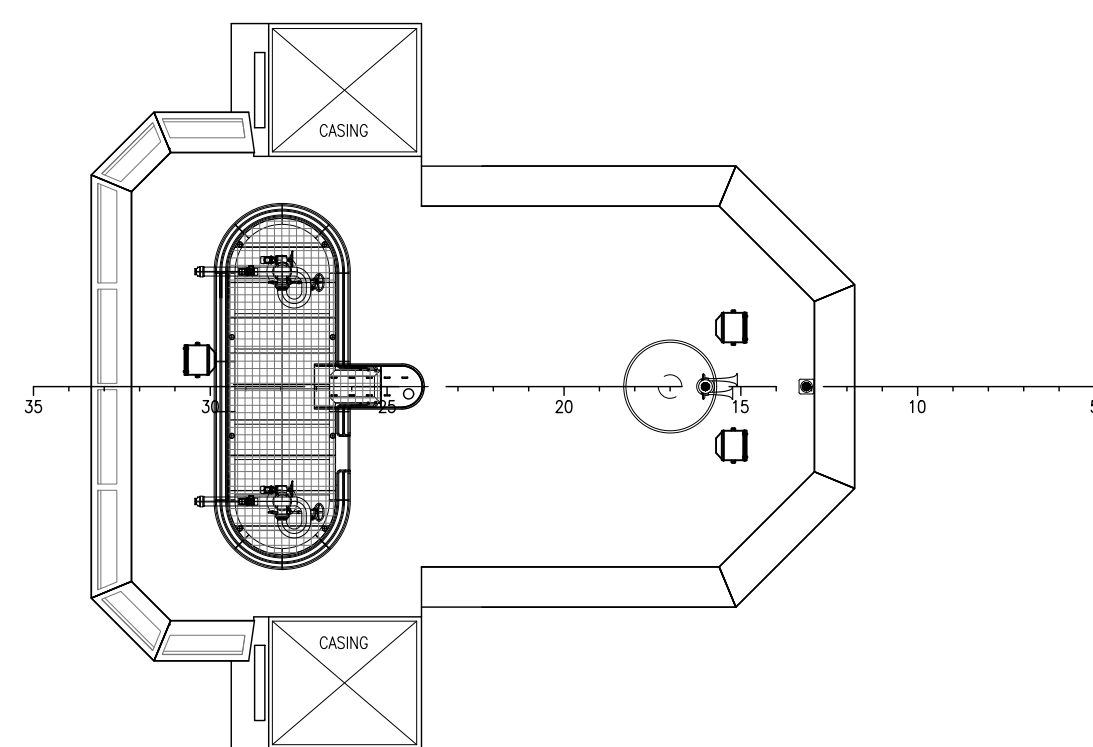

04 DECK PLAN
TOP OF HOUSE - 60'-5 1/2" ABL

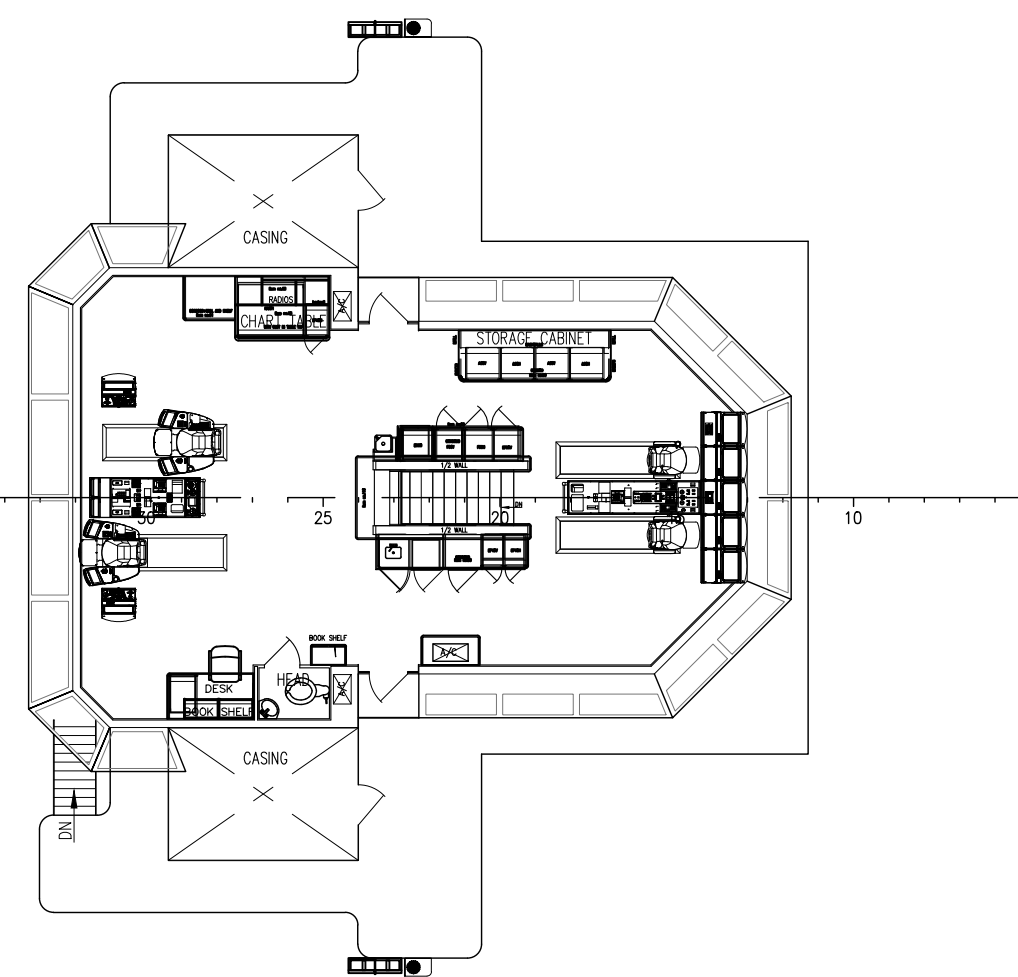

03 DECK PLAN
BRIDGE - 51'-4 5/8" ABL

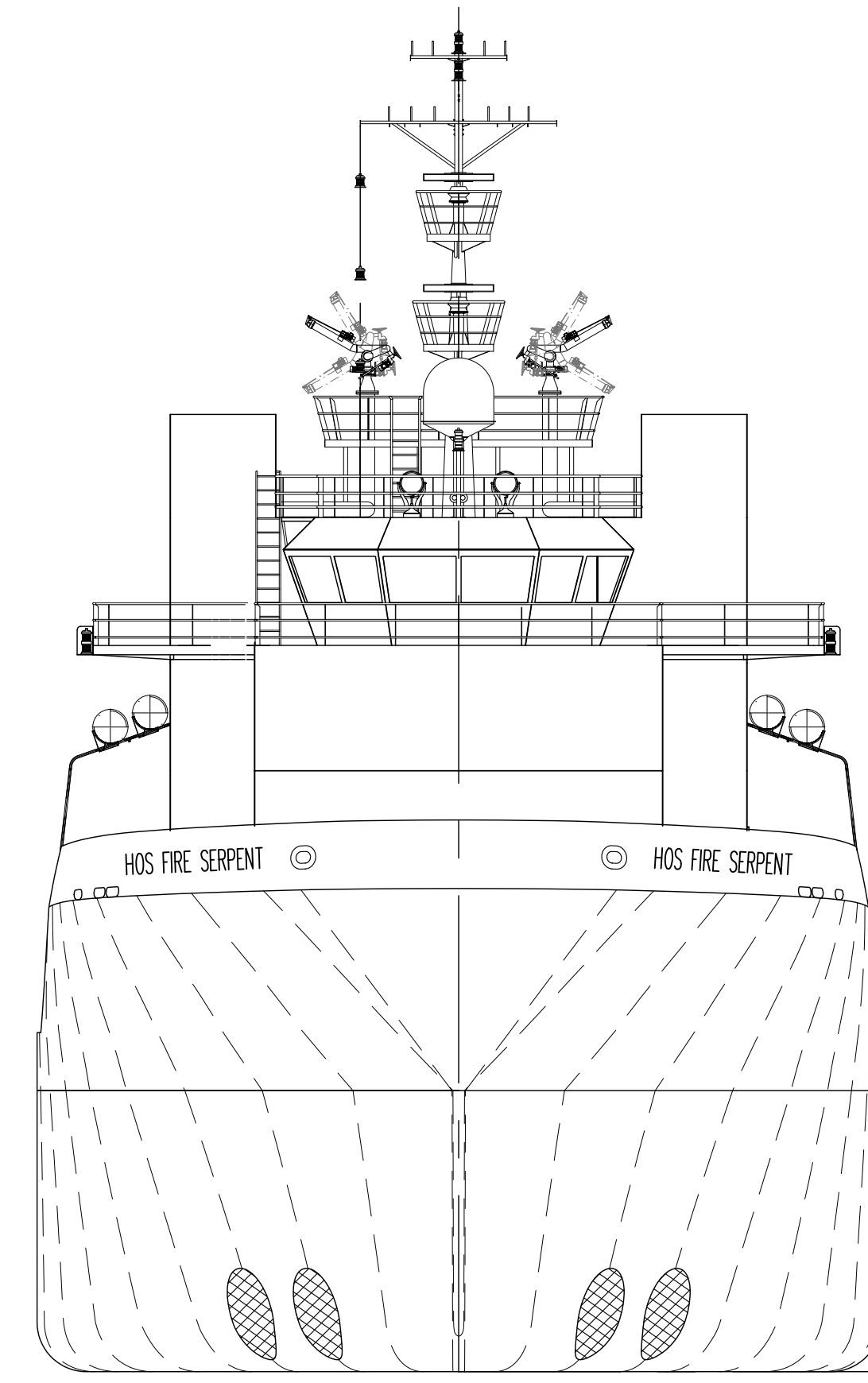

BOW PROFILE
LOOKING AFT

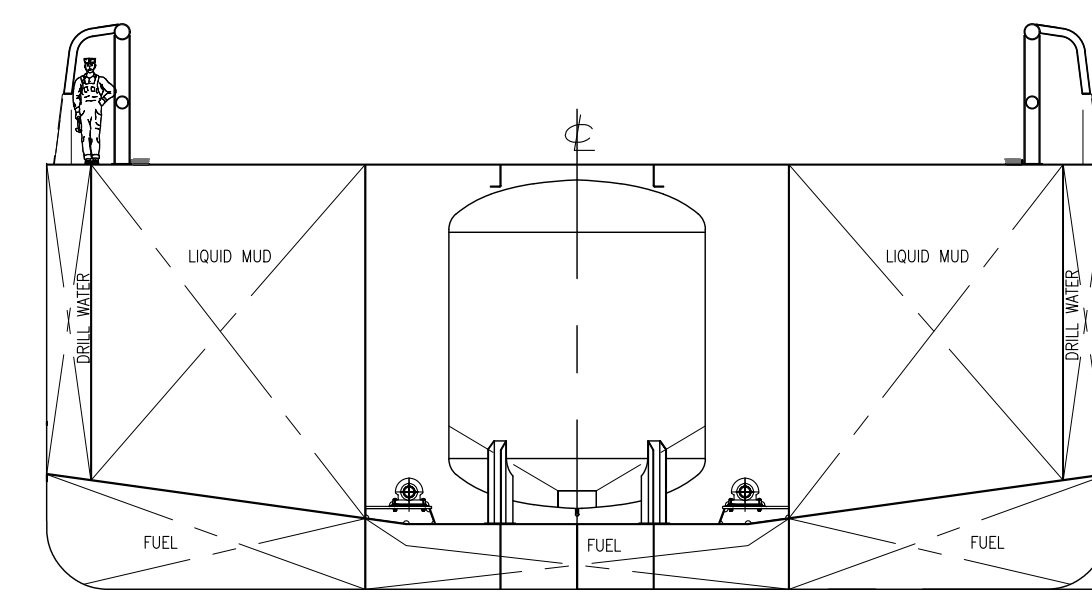

CARGO AREA SECTION
APPROX. FR85

 <p>THIS DRAWING, DESIGN CONCEPT AND SPECIFICATIONS ARE THE PROPERTY OF HORNBECK OFFSHORE SERVICES AND ARE FURNISHED ON A CONFIDENTIAL BASIS WITH AN EXPRESSED UNDERSTANDING THAT THEY WILL NOT BE COPIED IN ANY MANNER USED FOR MANUFACTURE, SALE, TRANSFER, NOR USED TO THE DETRIMENT OF SAID FIRM WITHOUT WRITTEN PERMISSION.</p> <p>HORNBECK OFFSHORE SERVICES</p>	<p>OUTBOARD PROFILE & GENERAL ARRANGEMENT</p>		<p>SIZE D</p>	
	<p>TASK No. 7582</p>	<p>DRAWING No. 1.001</p>	<p>SCALE: 3/32"=1'-0"</p>	<p>REV. 2</p>
	<p>HULL No. 260</p>	<p>SY: NAS</p>	<p>DATE: 03/03/22</p>	<p>SHEET 3 OF 3</p>

24

23

22

21

20

19

18

17